

Together with pieces in page 11
Junto a las piezas de la página 11

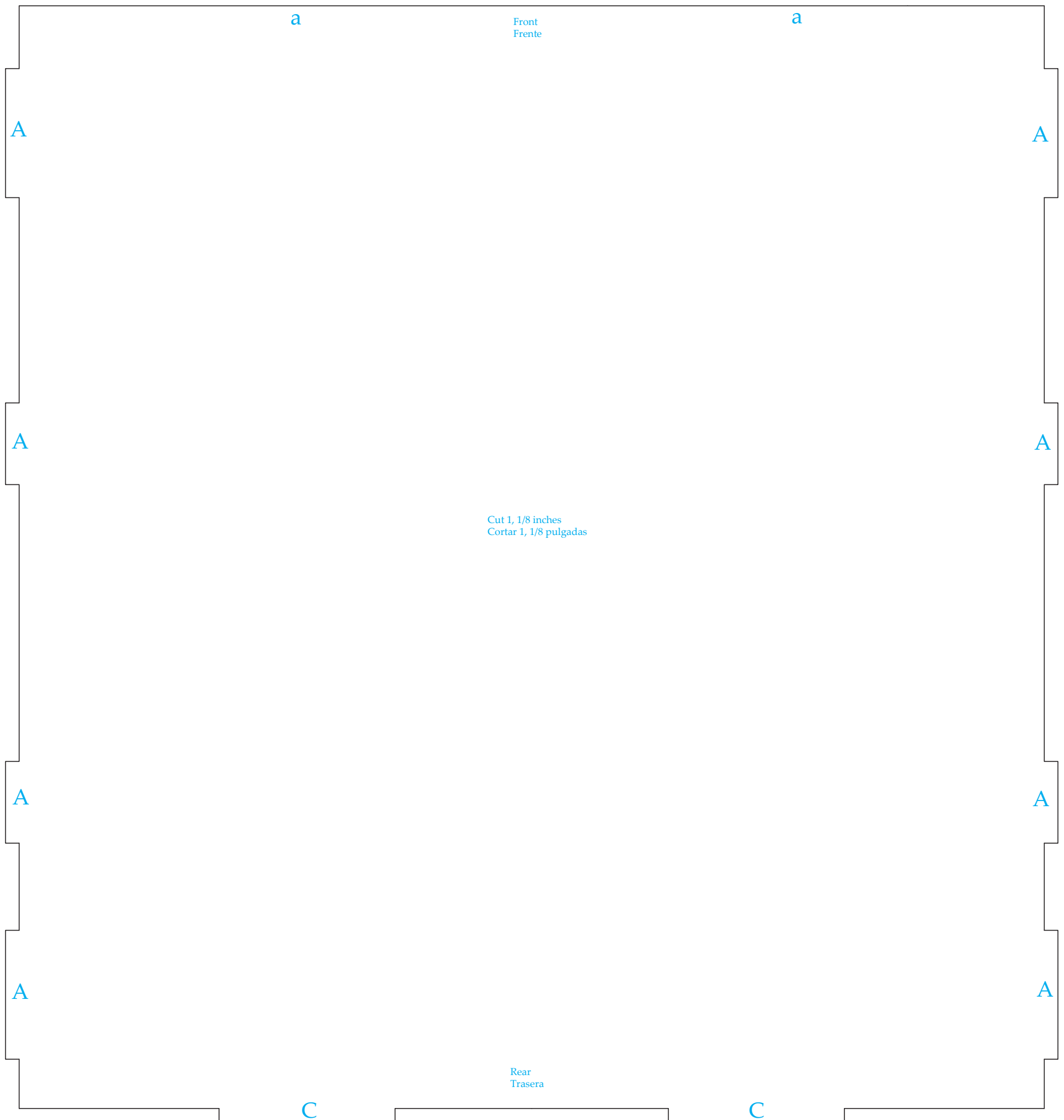

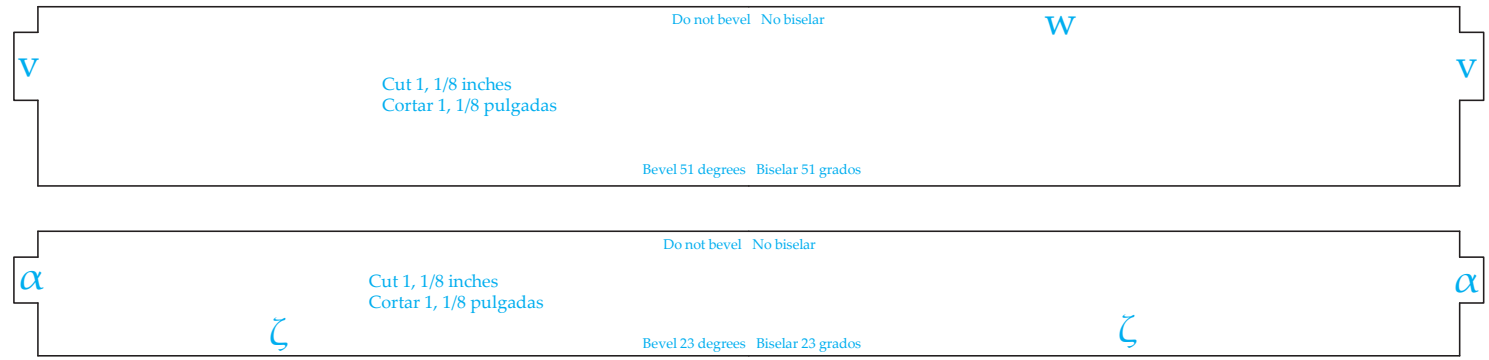
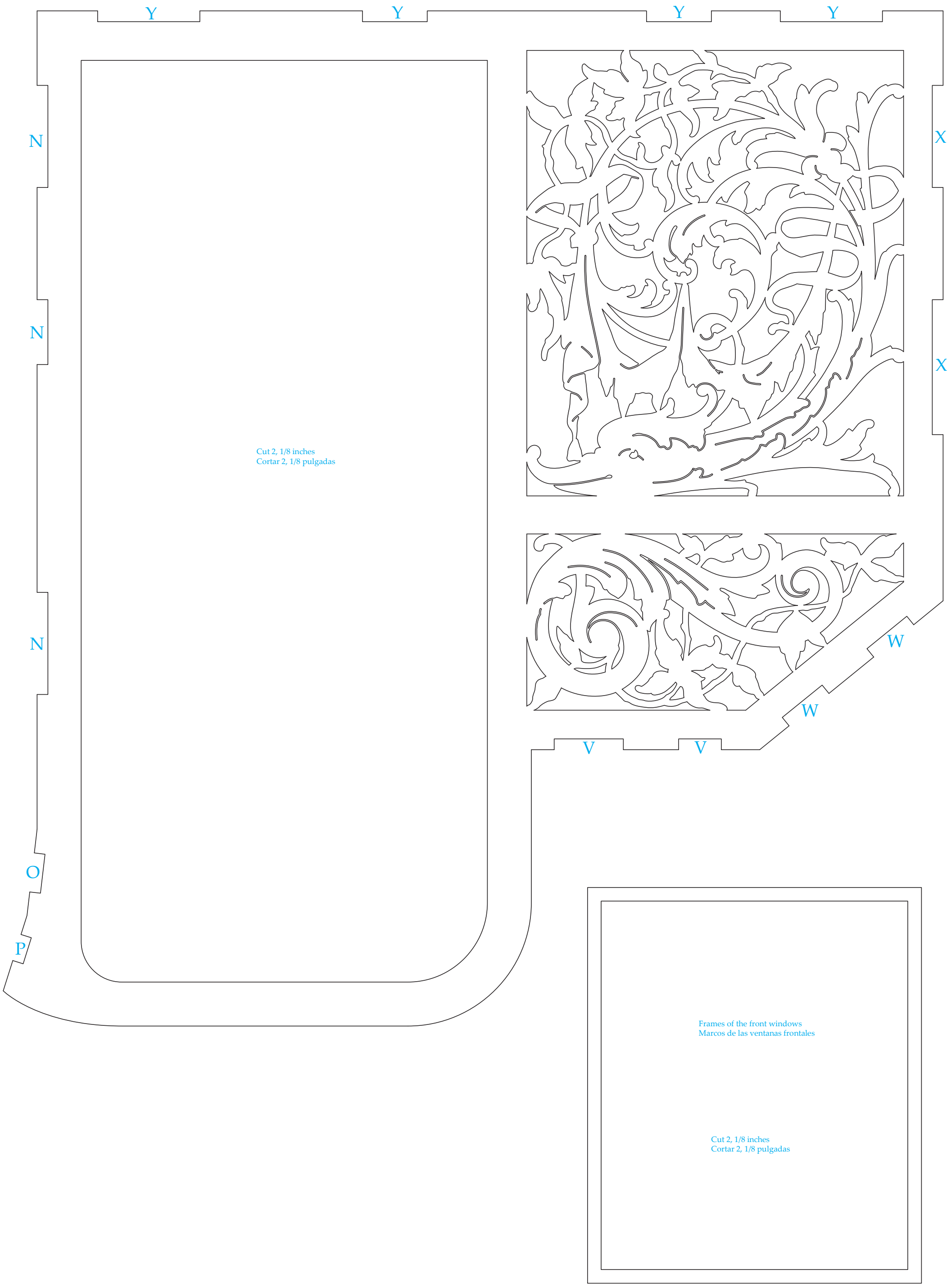

Cut 2, 1/8 inches
Cortar 2, 1/8 pulgadas

Frames of the front windows
Marcos de las ventanas frontales

Cut 2, 1/8 inches
Cortar 2, 1/8 pulgadas

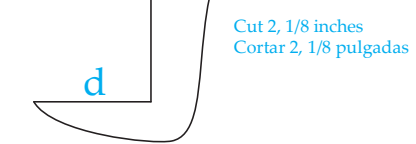
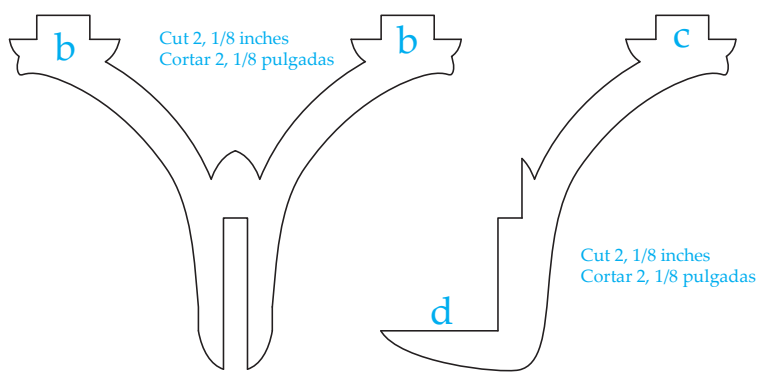
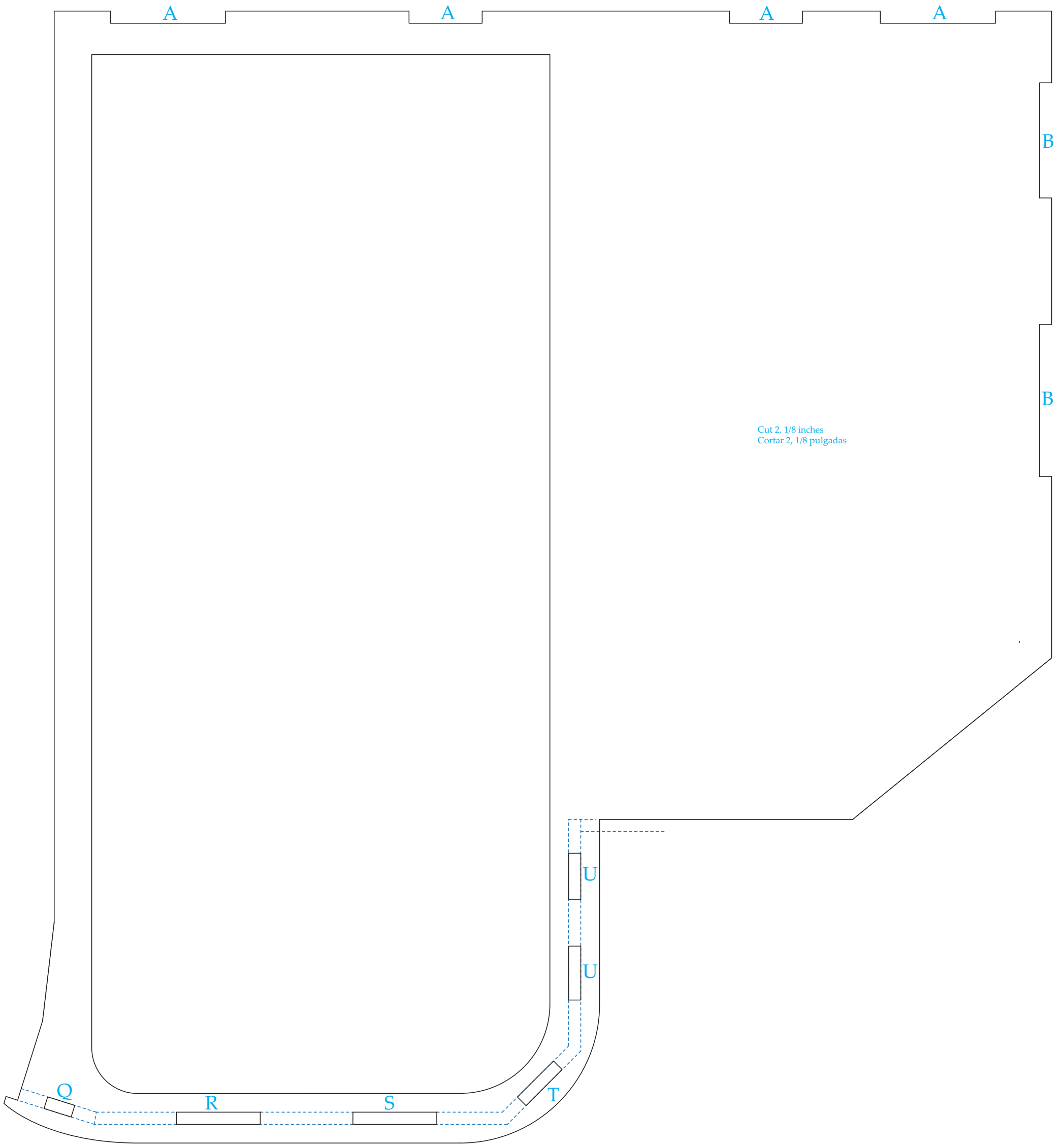

Cut 1, 1/8 inches
Cortar 1, 1/8 pulgadas

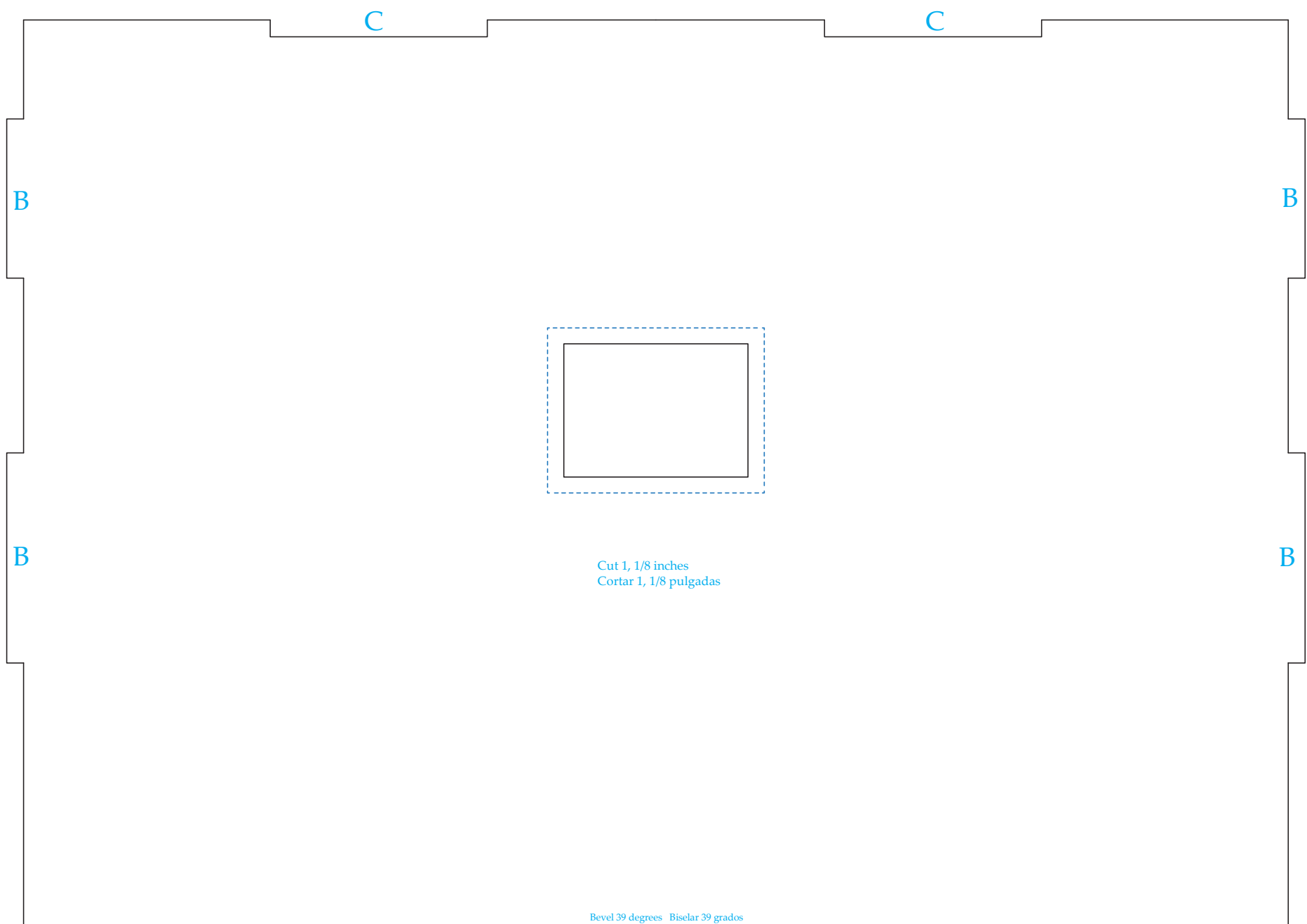
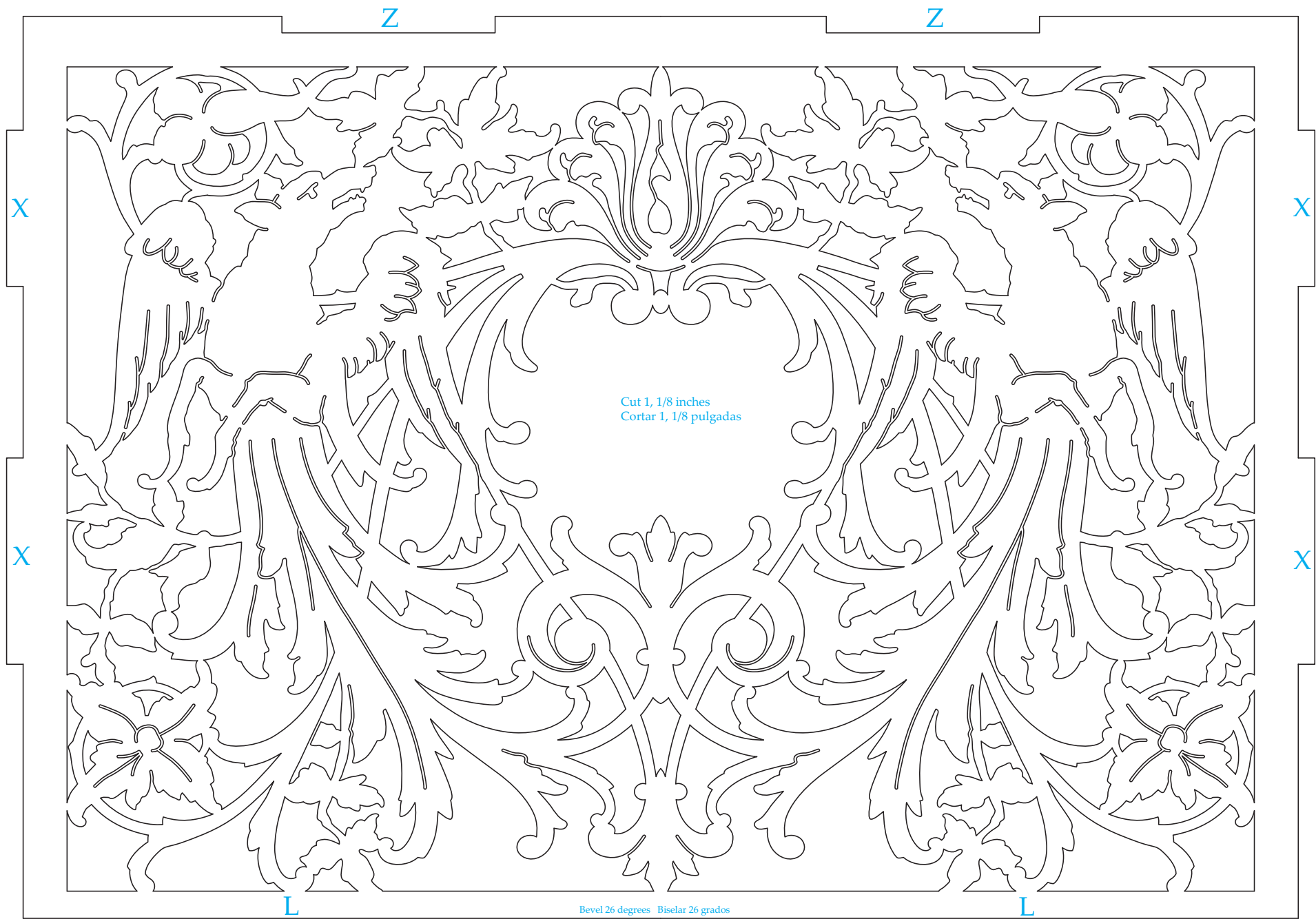

Together with pieces in page 11
Junto a las piezas de la página 11

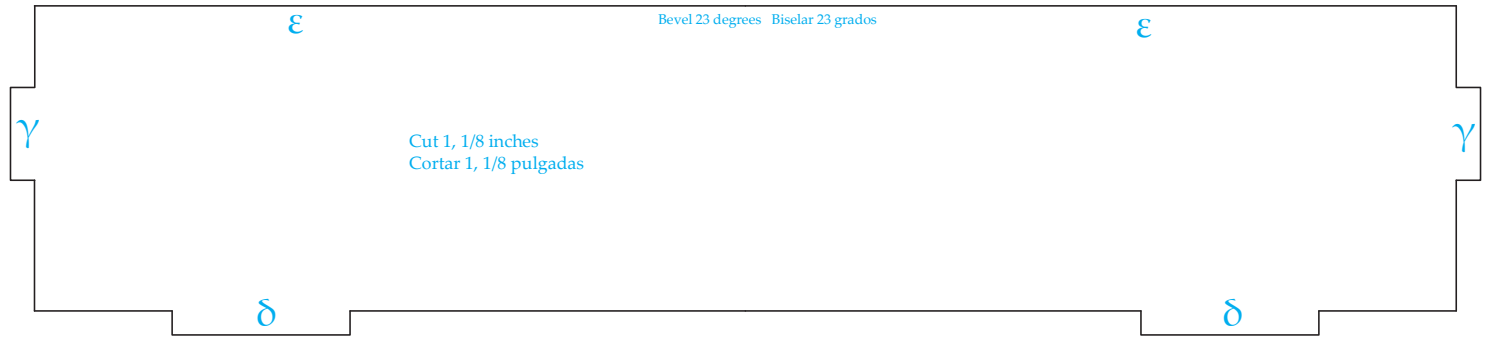
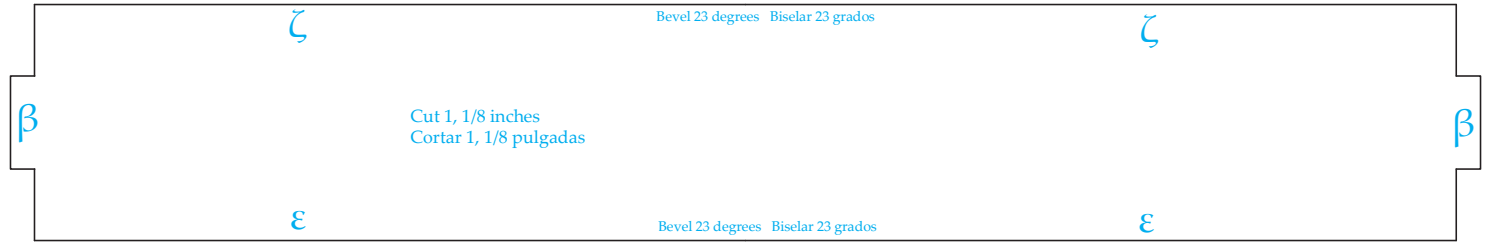

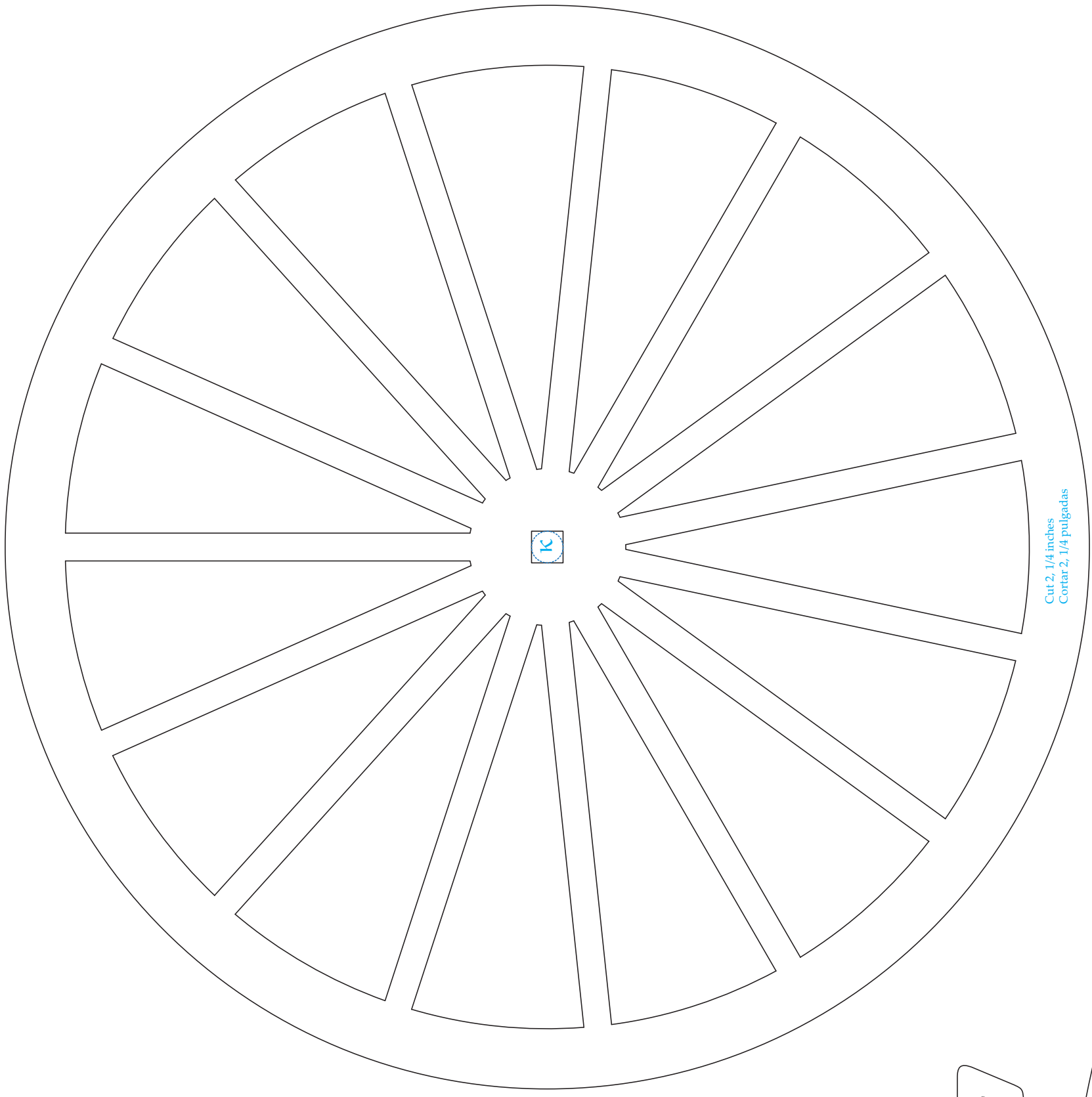

Cut 2, 1/4 inches
Cortar 2, 1/4 pulgadas

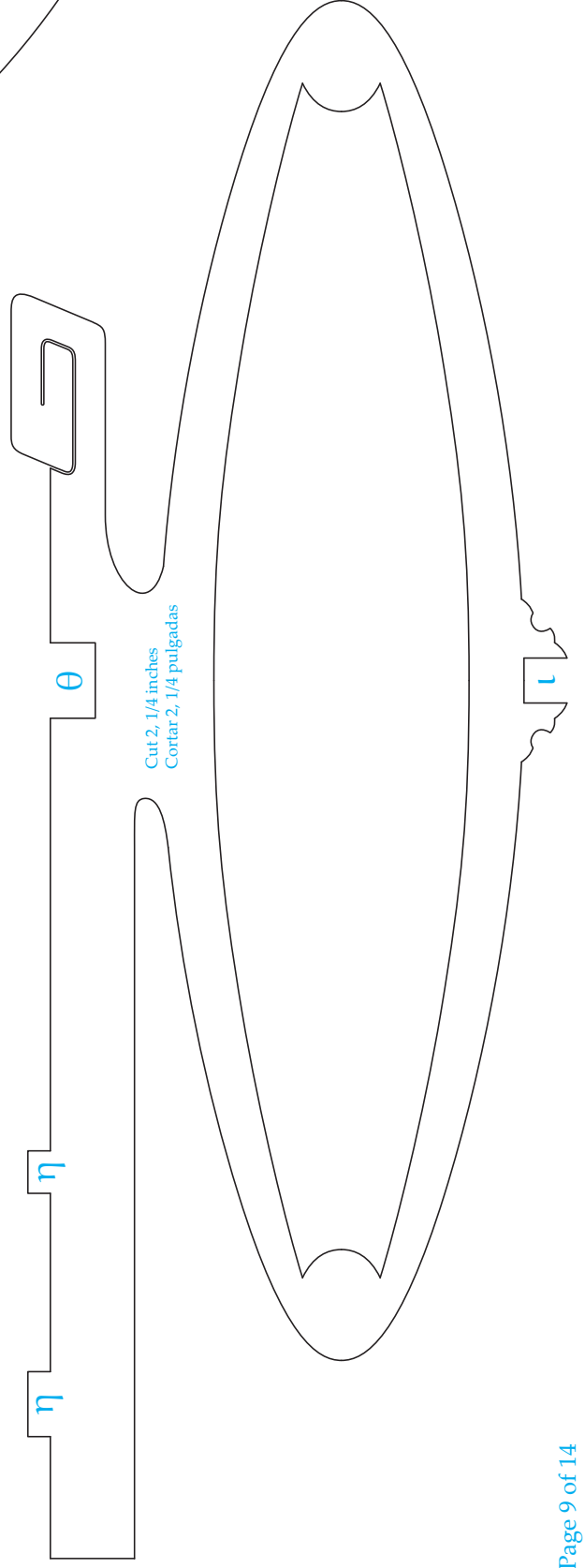

Cut 2, 1/4 inches
Cortar 2, 1/4 pulgadas

Cut 2, 1/8 inches
Cortar 2, 1/8 pulgadas

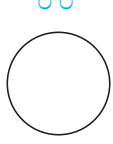

Cut 2, 1/8 inches
Cortar 2, 1/8 pulgadas

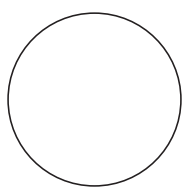

Cut 2, 1/8 inches
Cortar 2, 1/8 pulgadas

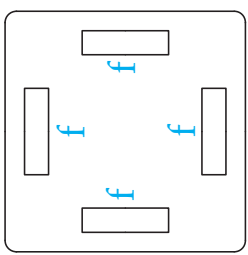

Cut 6, 1/8 inches
Cortar 6, 1/8 pulgadas

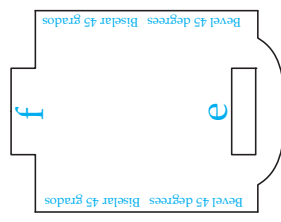

Cut 2, 1/8 inches
Cortar 2, 1/8 pulgadas

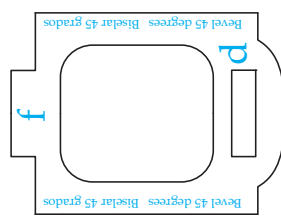

Cut 2, 1/8 inches
Cortar 2, 1/8 pulgadas

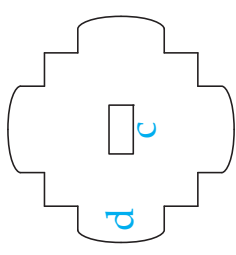

Cut 2, 1/8 inches
Cortar 2, 1/8 pulgadas

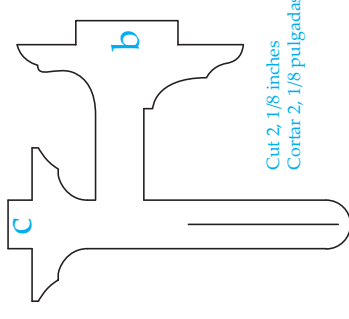

Cut 4, 1/8 inches
Cortar 4, 1/8 pulgadas

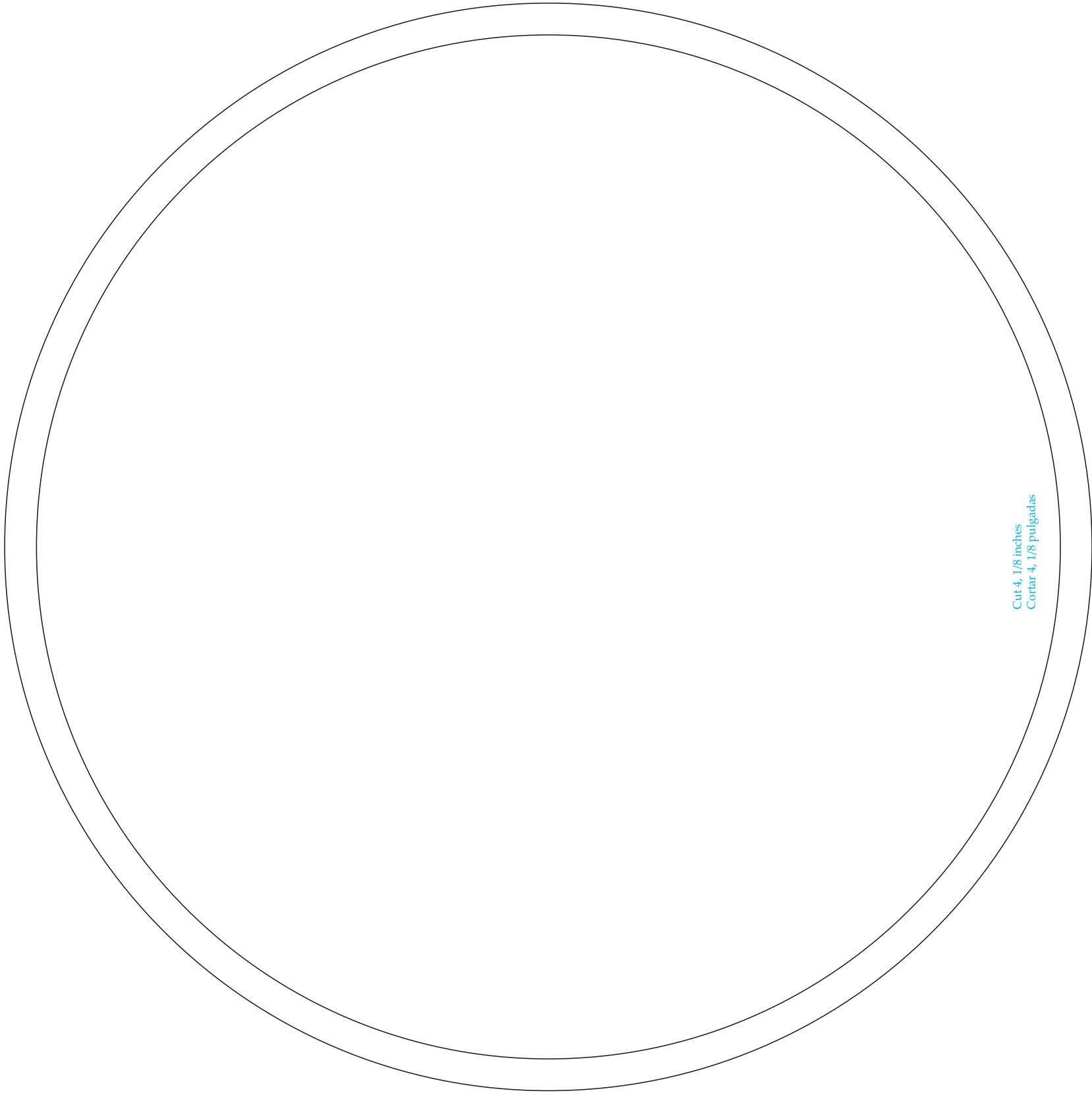

Cut 1, 1/4 inches
Cortar 1, 1/4 pulgadas



Cut 1, 1/4 inches
Cortar 1, 1/4 pulgadas

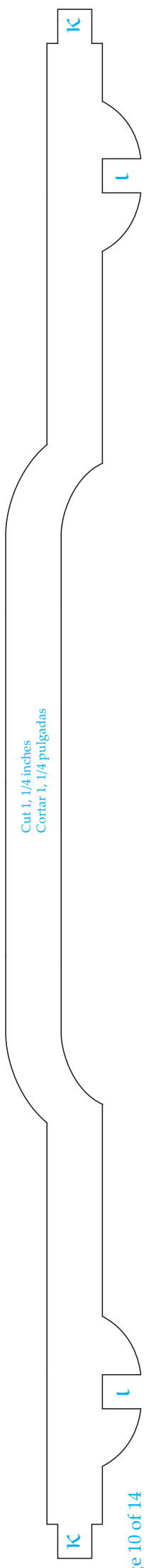

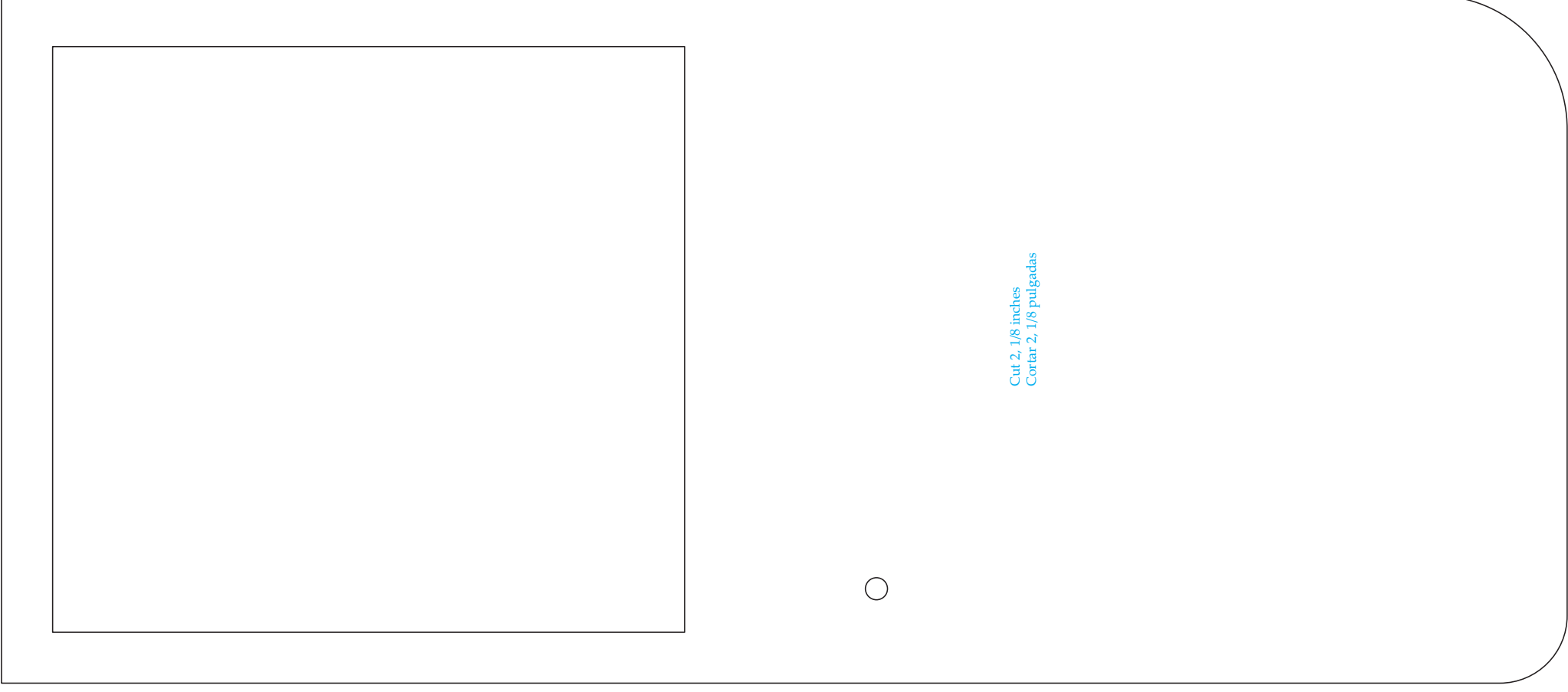

Cut 2, 1/8 inches
Cortar 2, 1/8 pulgadas



Cut 2, 1/8 inches
Cortar 2, 1/8 pulgadas



Cut 2, 1/8 inches
Cortar 2, 1/8 pulgadas



Cut 2, 1/8 inches
Cortar 2, 1/8 pulgadas



Cut 2, 1/8 inches
Cortar 2, 1/8 pulgadas

Use a stick of this diameter for the lock
Utilice un palito de este diámetro para el cierre

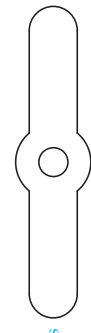

Cut 2, 1/8 inches
Cortar 2, 1/8 pulgadas

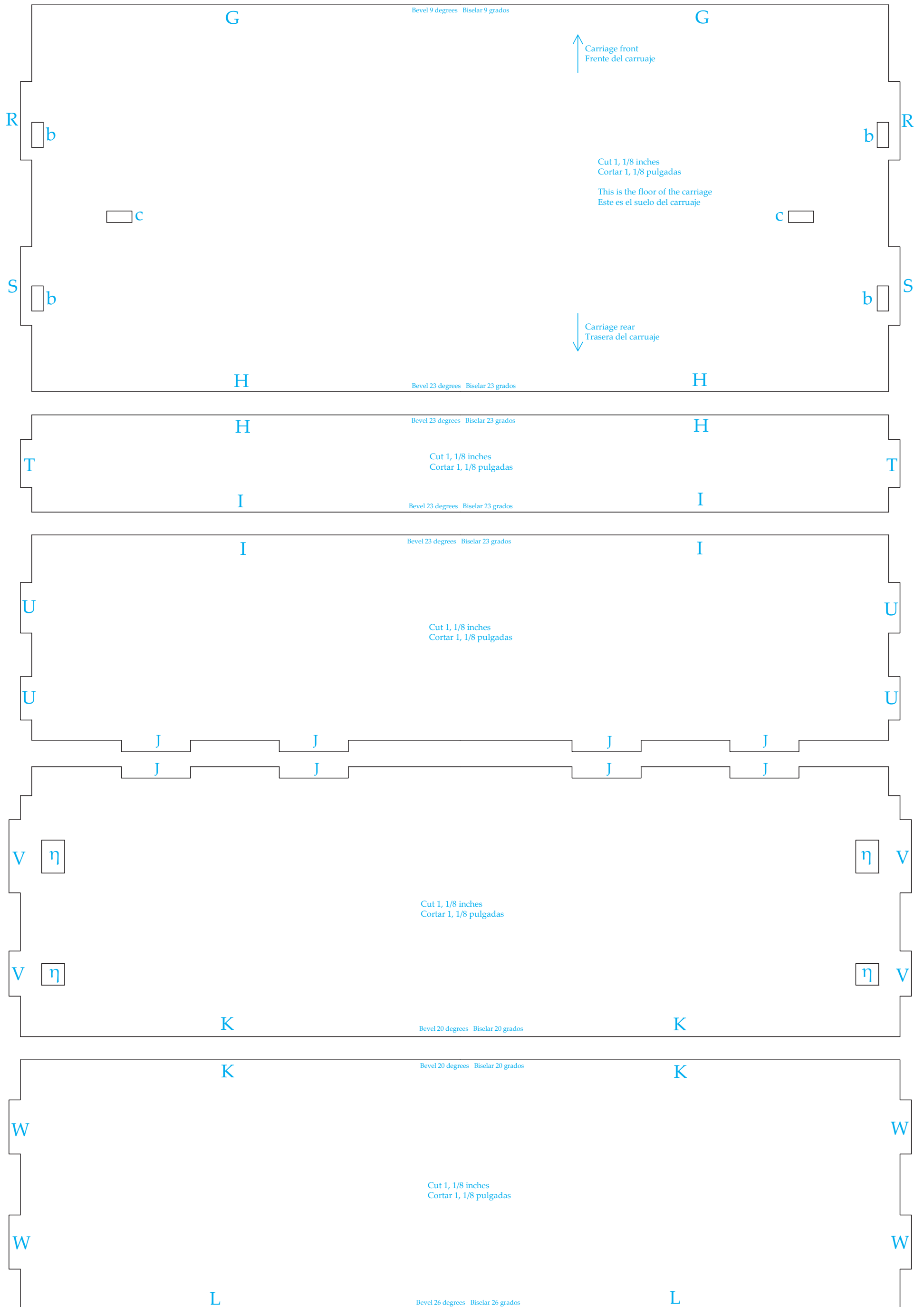

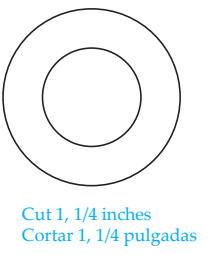
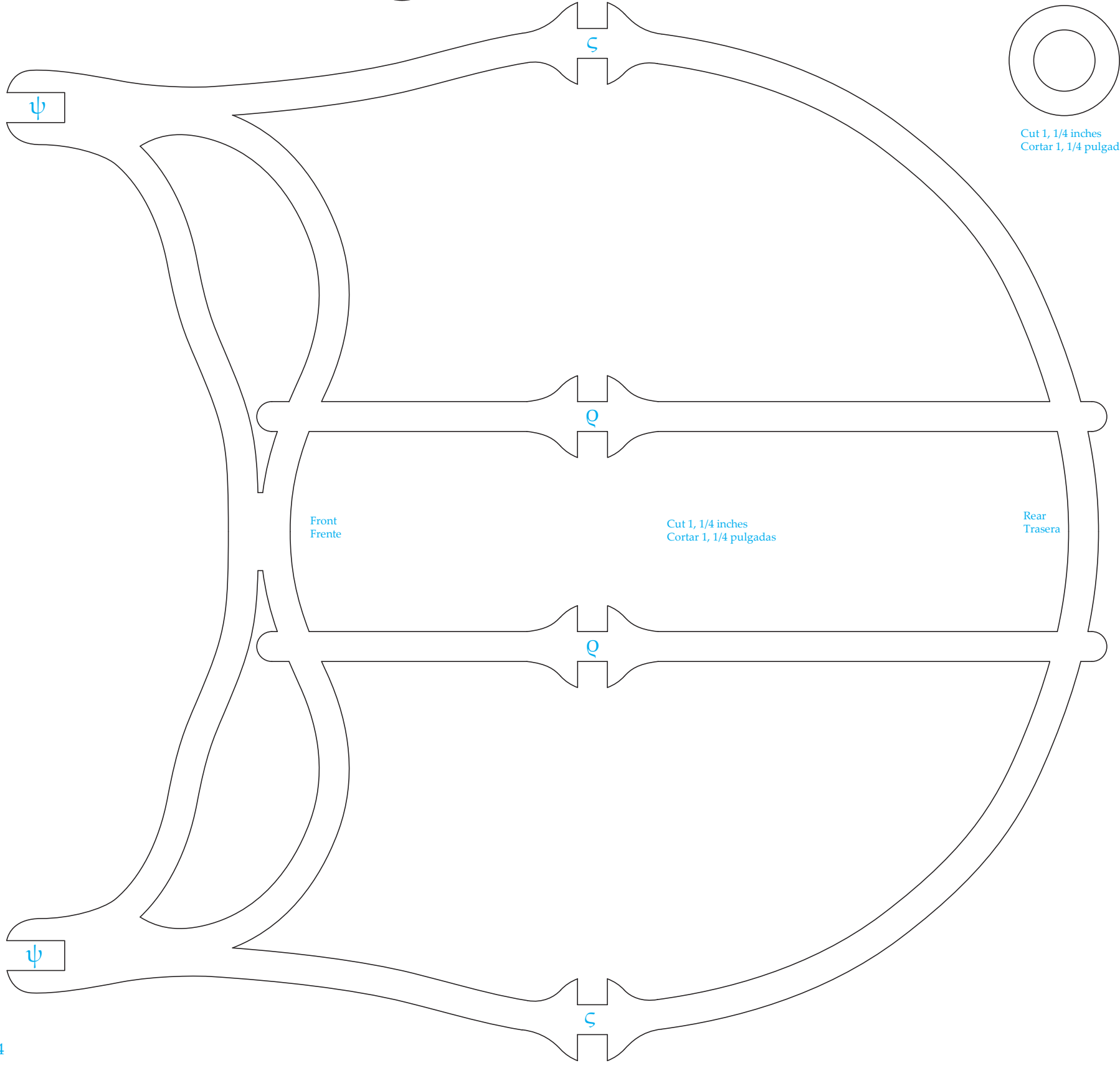
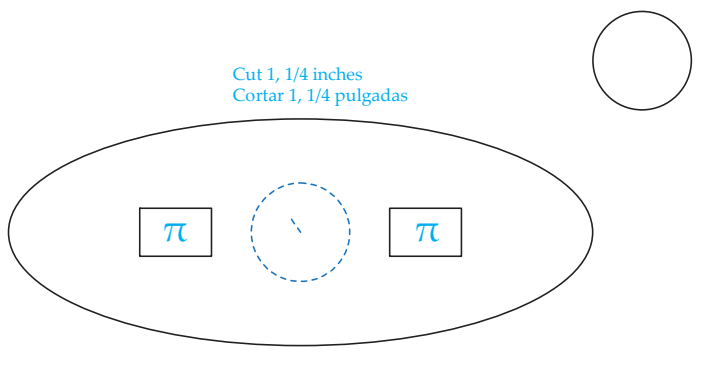
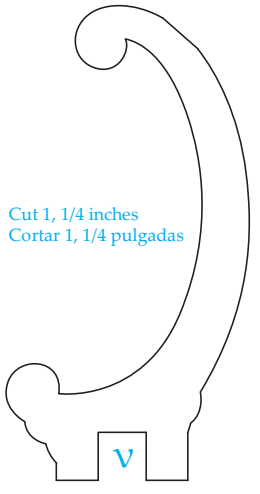
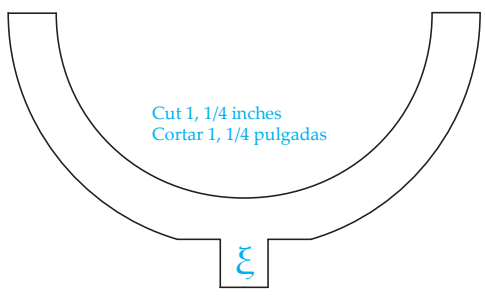
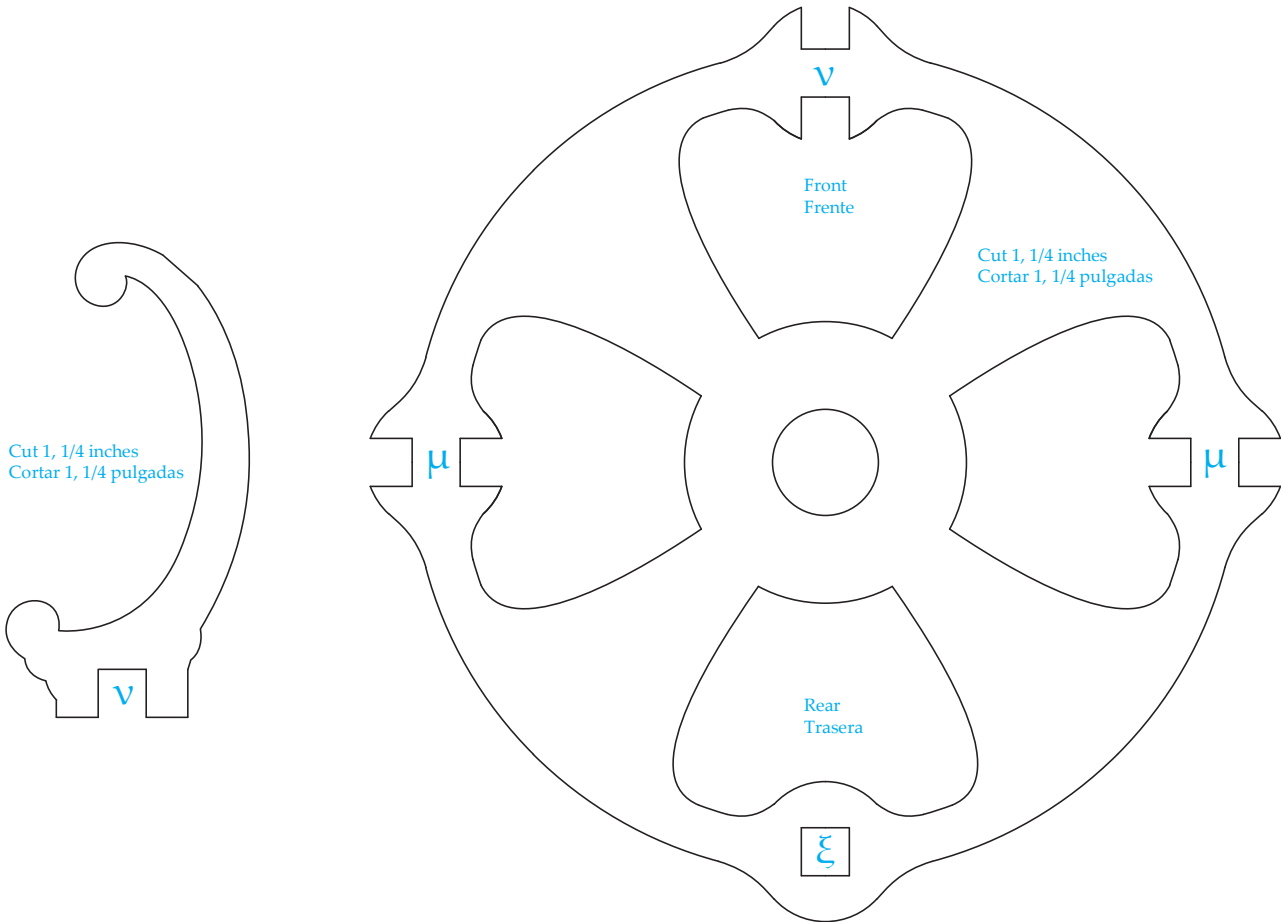
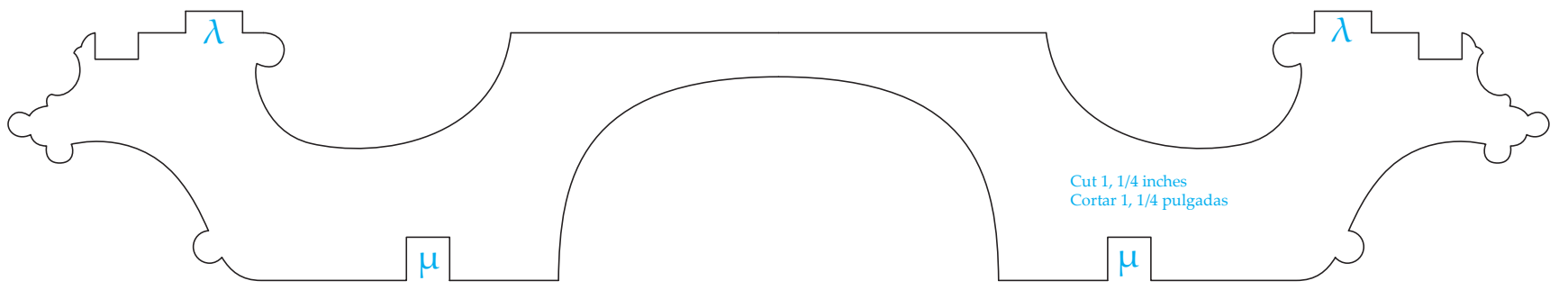

If you want the wheels to rotate you may need to make these rods longer and round. Also, use the round inner cuts (dotted blue lines) in the wheels instead of the square ones. Plan in advance the necessary changes

Si desea que las ruedas puedan rotar, usted puede necesitar hacer estas partes más largas y redondeadas. Utilice el corte interior circular en las ruedas (línea azul punteada) en lugar del cuadrado. Planee de antemano los cambios necesarios.

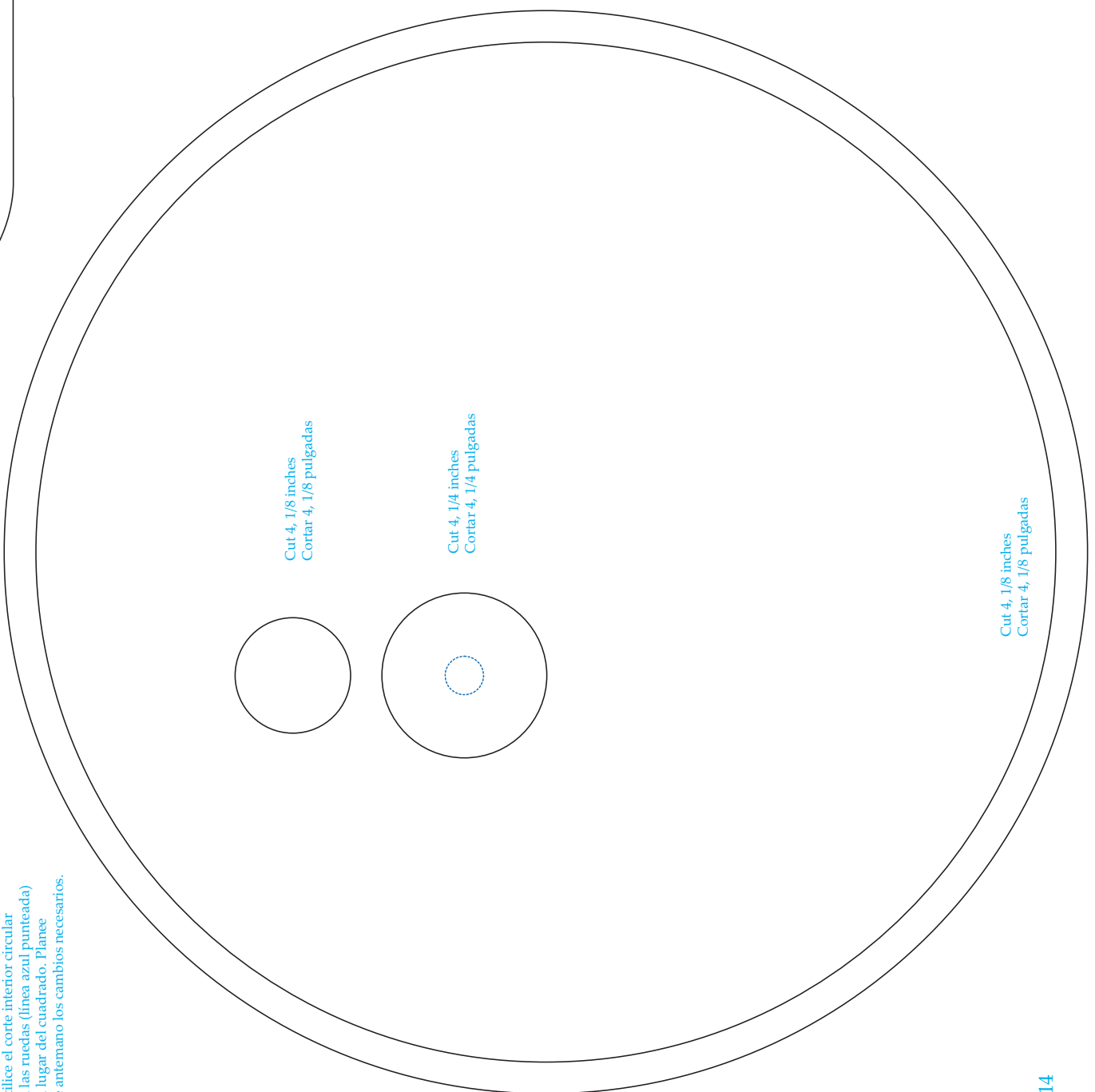
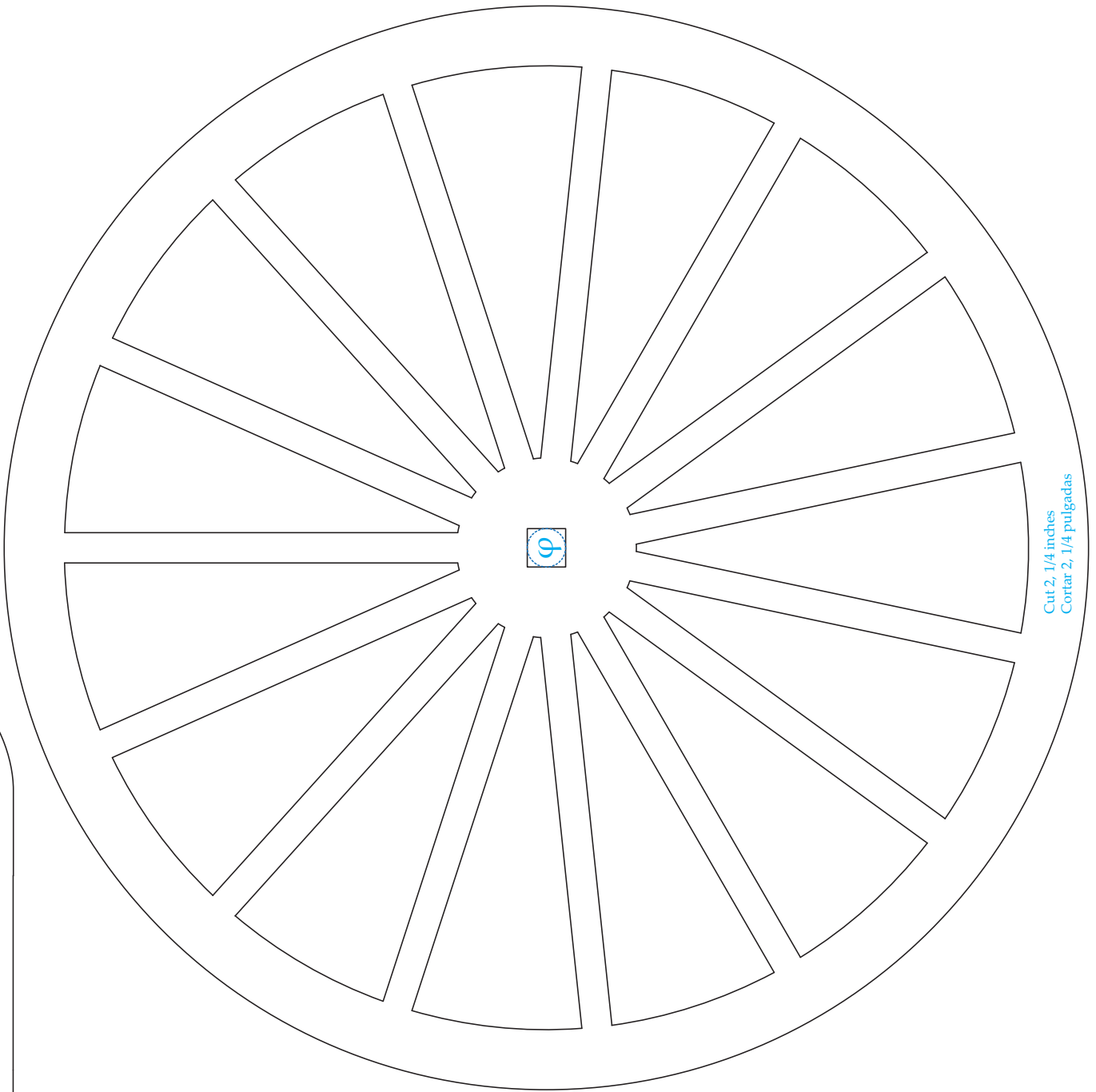
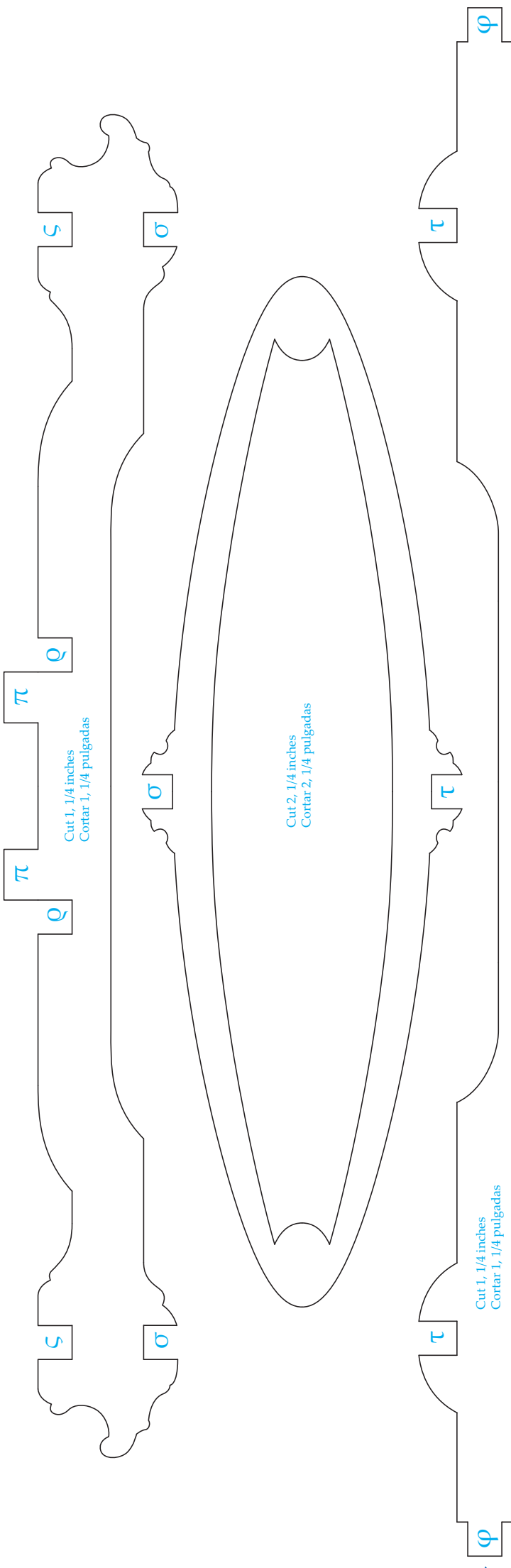

Cut 4, 1/8 inches
Cortar 4, 1/8 pulgadas

Cut 2, 1/4 inches
Cortar 2, 1/4 pulgadas

